



MIRILLA DE DOBLE VISOR

SIGHT GLASS WITH DOUBLE GLASS

NORMAS DIN

**Fig. VS
114**

**SERIE
PN-10**

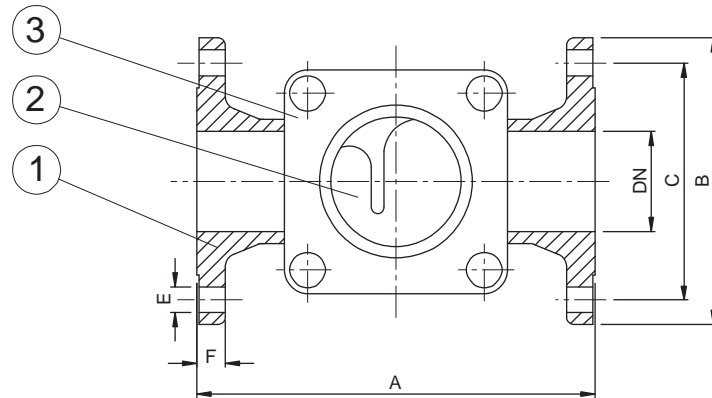

- SOBRE DEMANDA SE PUEDE BARRENAR LAS BRIDAS S/N ASA.
- LOS CRISTALES DE SERIE SON AKLO 250.
- BAJO DEMANDA PODEMOS MONTAR LA CALIDAD QUE NOS SOLICITEN.

- ON REQUIREMENT WE CAN DRILL FLANGES ACCORDING ASA STANDARD
- GLASSES ARE AKLO 250
- WE CAN ASSEMBLY THE KIND OF GLASS YOU DEMAND.

Nº	DENOMINACIÓN / PART	MATERIAL
1	CUERPO / BODY	INOX CF8M
2	CRISTAL / GLASS	BOROSILICATE
3	TAPA / COVER	INOX CF8M

Otros materiales / dimensiones consultar
Others materials / dimensions on request

SIGHT GLASS WITH DOUBLE GLASS

- Bolted bonnets.
- Special glass disc for any fluid or temperature.
- Drilled and dimensioned flanged according to DIN PN-10.
- Distance between sides according DIN 3202 F-1.
- Sizes from 15 to 200 mm.

MIRILLAS DE DOBLE VISOR

- Tapas atornilladas.
- Discos en vidrio especiales para cualquier producto o temperatura.
- Bridas dimensionadas y barrenadas s/n DIN PN-10.
- Distancia entre caras s/n DIN 3202 F-1.
- Pasos de 15 a 200 mm.

CUADRO DE DIMENSIONES NORMAS DIN

DIMENSIONS PANEL

DN	15	20	25	32	40	50	65	80	100	125	150	200
A	130	150	160	180	200	230	290	310	350	400	480	600
B	95	105	115	140	150	165	185	200	220	250	285	340
C	65	75	85	100	110	125	145	160	180	210	240	295
F	14	16	16	16	18	18	18	20	20	22	22	24
E	14	14	14	18	18	18	18	18	18	18	23	23
N*	4	4	4	4	4	4	4	8	8	8	8	8/12

* N° de agujeros / N° of holes