



VALVULA DE RETENCION CLAPETA

CHECK VALVE BY DISC

NORMAS ANSI

**Fig. VS
133**

**SERIE
150 Lbs**

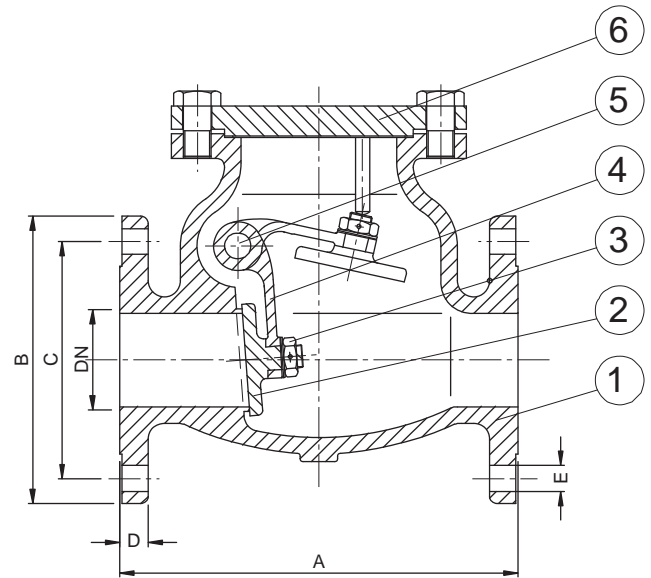

Nº	DENOMINACIÓN / PART	MATERIAL
1	CUERPO / BODY	INOX CF8M
2	CIERRE / DISC	INOX CF8M
3	TUERCA / NUT	INOX 316
4	BIELA / ARM	INOX CF8M
5	EJE / HINGE	INOX CF8M
6	TAPA / COVER	INOX CF8M

Otros materiales / dimensiones consultar
Others materials / dimensions on request

CUADRO DE DIMENSIONES NORMAS DIN							
DIMENSIONS PANEL							
DN	A	B	C	D	E	Nº Agujeros Nº of Holes	Peso (kg) Weight (kg)
2"	203,2	152	120,6	16	20	4	13
3"	241,3	191	152,4	19,5	20	4	22
4"	292,1	229	190,5	24	20	8	42
6"	355,6	279	241,3	25,5	23	8	70
8"	495,3	343	298,4	29	23	8	110
10"	622,3	406	361,9	30,5	26	12	204
12"	698,5	483	431,8	32	26	12	306